

Type 570
2Serve - service and self-service case

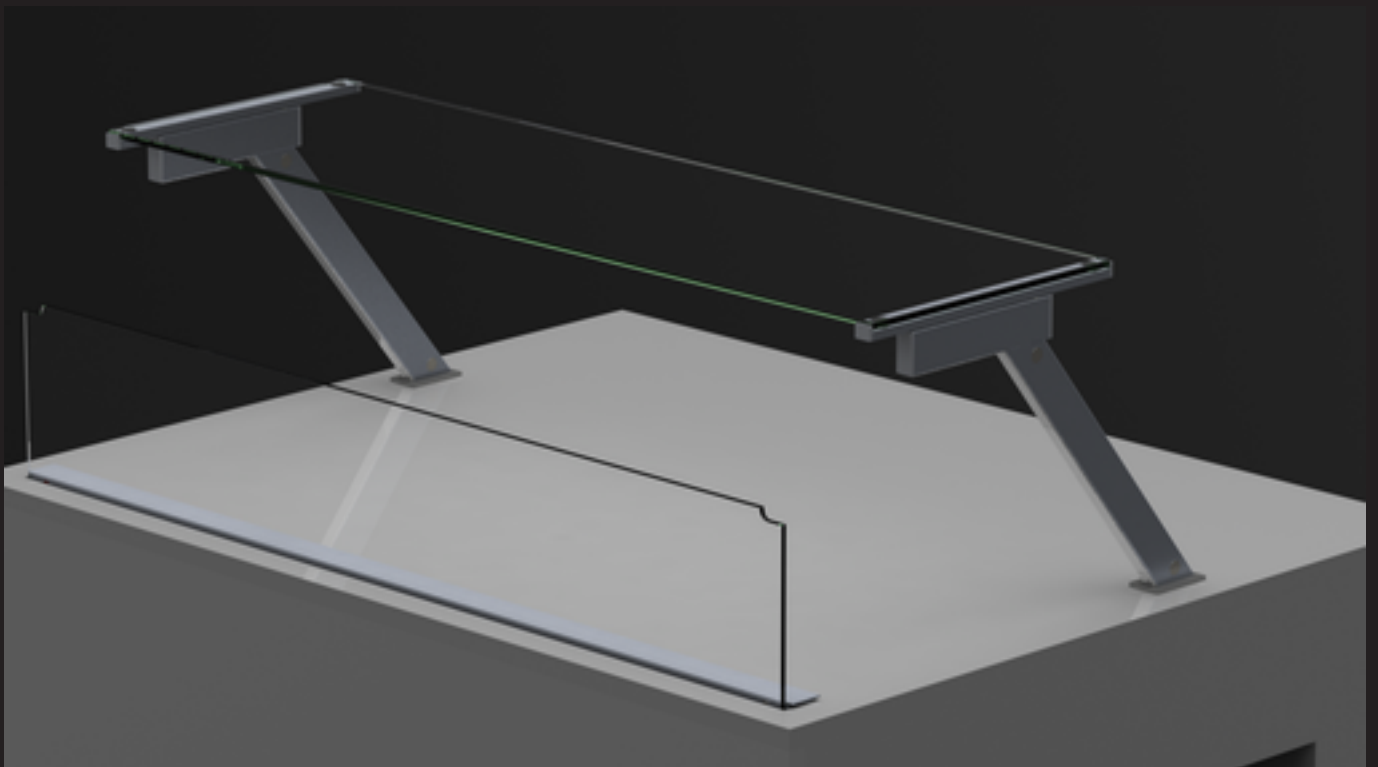

Product characteristics

- hardware series for conversion from service to self-service case
- motor driven retractable front glass (230V AC/ 50 Hz; 345W)
(operate only by push and hold button, not by switch)
- for 6 and 8 mm front glass
- glass weight of 7 up to 17 kg
- automatic cover with retracted front glass
- movable top service plate
- strut assembly in front, center or rear position

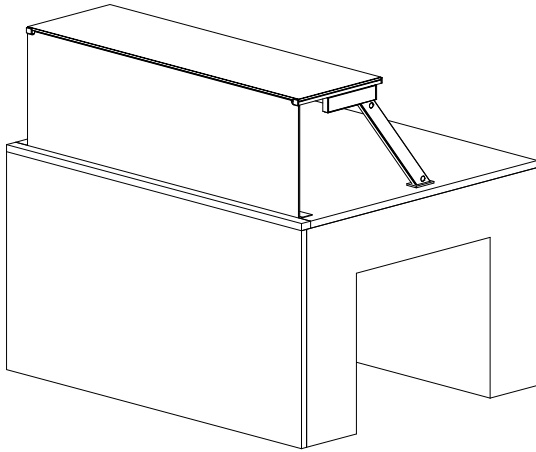

a) Front glass and top service plate closed

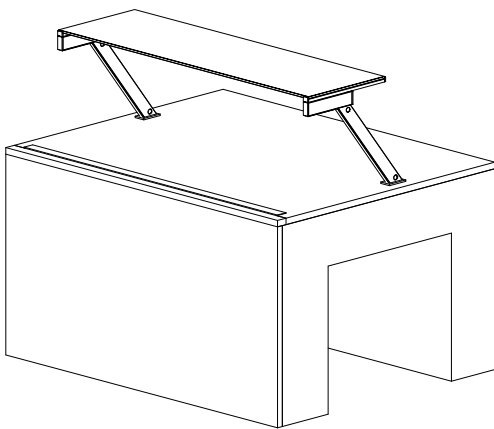

b) Front glass and top service plate open

Planning information

Necessary assembly dimensions of retractable front glass hardware

Delivery as a kit.

■ Standard Version (example)

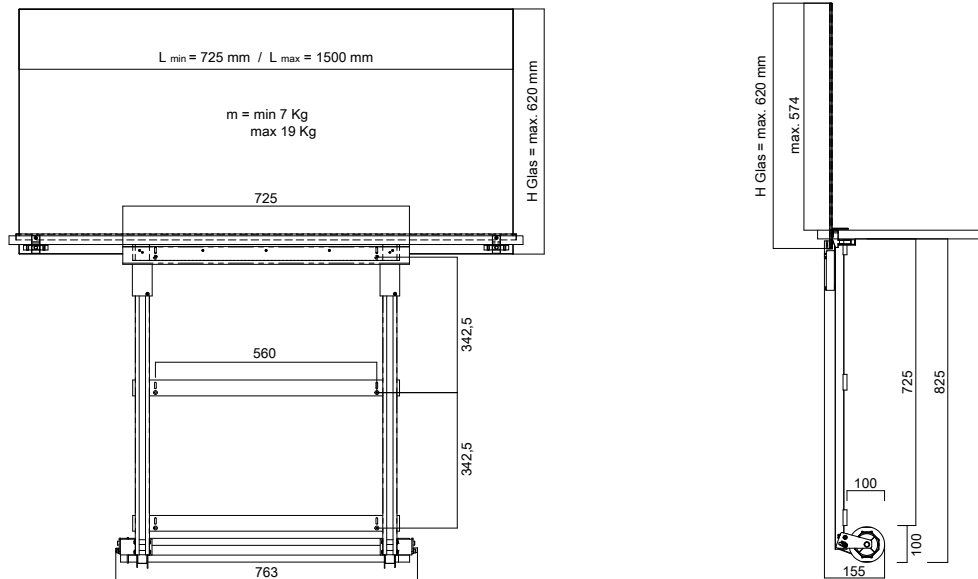

■ Shortened version (example)

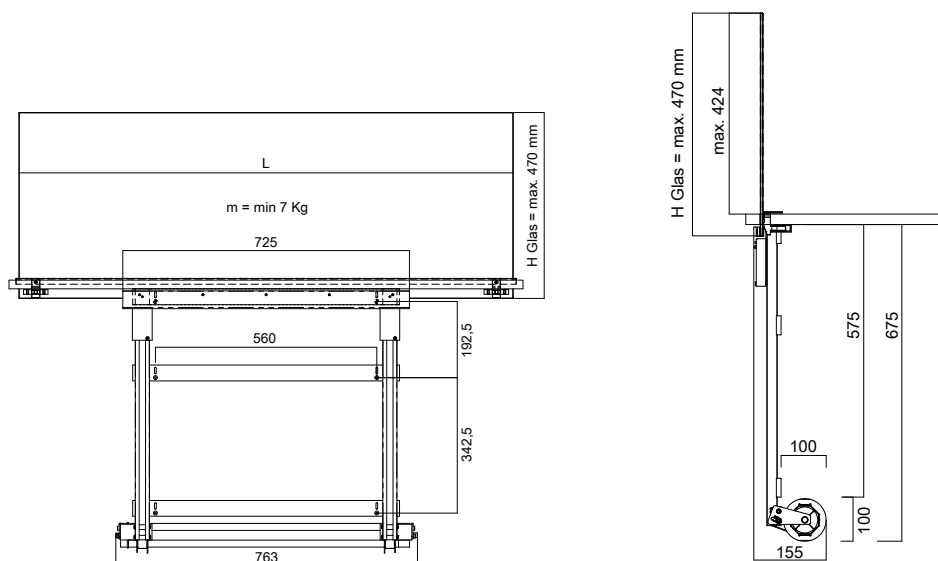

Assembly dimensions self-closing cover strip

Cover strip provided in 1.500 mm length, to be shortened by customer if required.

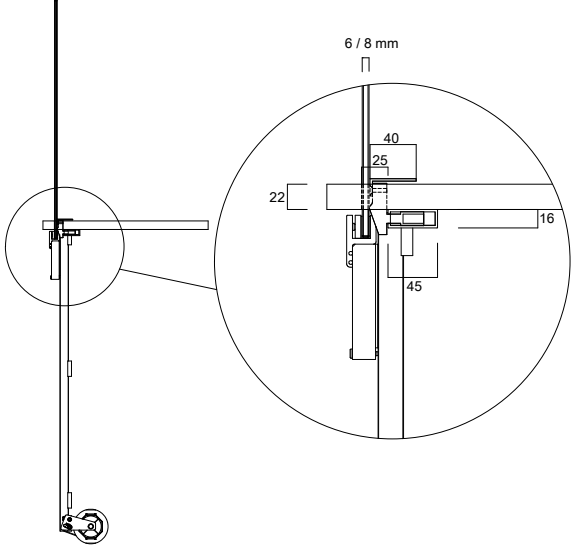

Definition of bottom position of front glass

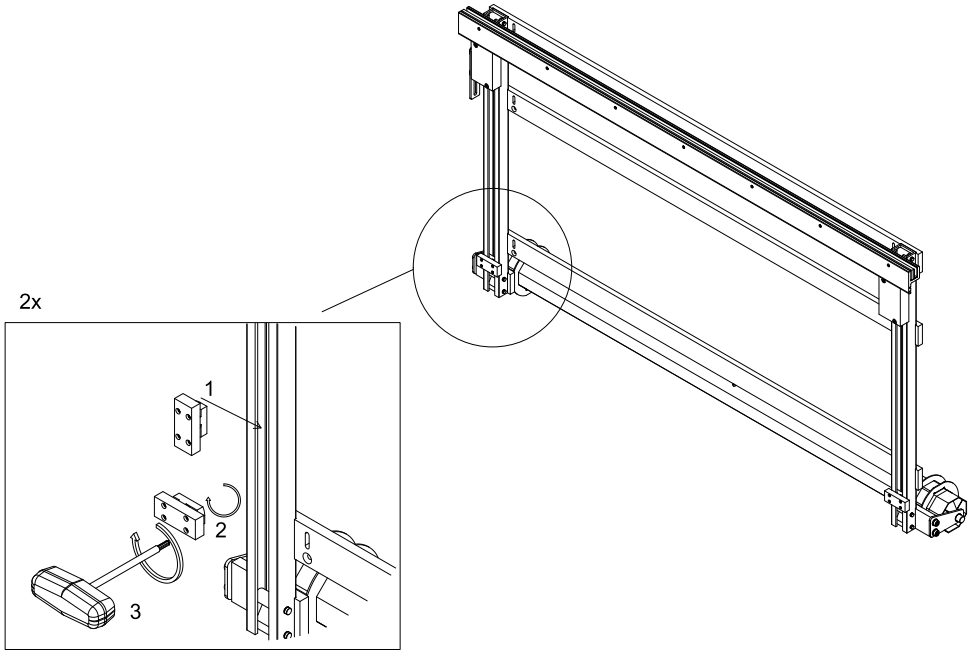

- 1) Insert strikers into left and right side.
- 2) Turn around by 90°.
- 3) Screw.

Mounting position of front suspension

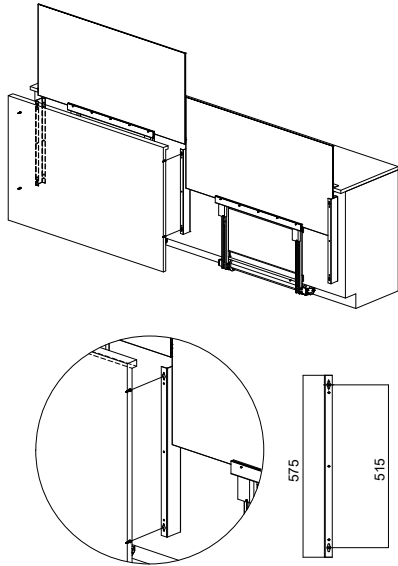

Moving distance and length of top service plate

- **Center strut (one or two sliding rails)**

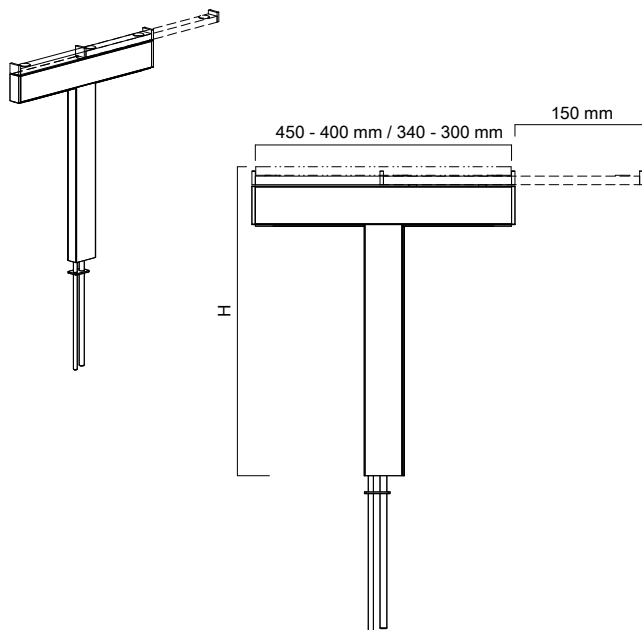

■ **Front strut (one or two slinding rails)**

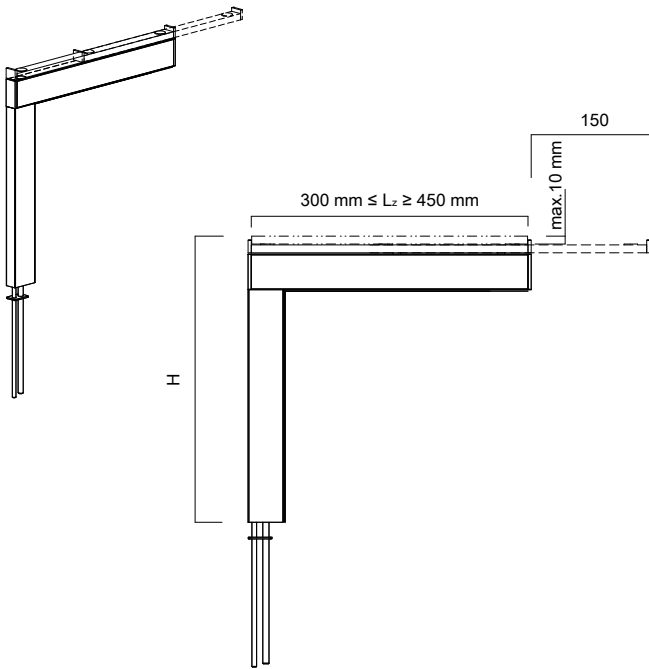

■ **Rear strut (one or two slinding rails)**

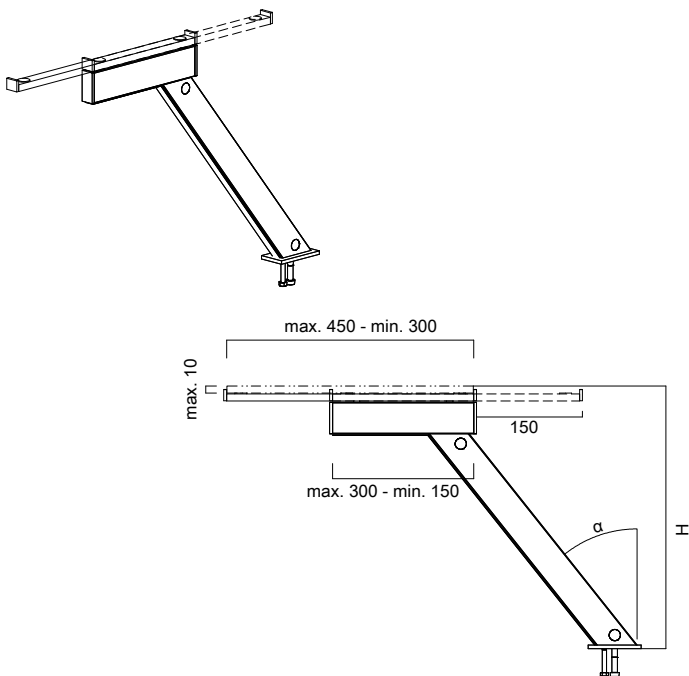

Use motor cable to program end positions of electric motor.

Type 570
Picture

Product

Part number

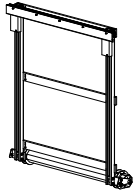

Type 570, retractable front glass hardware
Connection data engine:
230V AC/50Hz; 345W

18.449.2100.XXX



Type 570, front suspension
for mounting a front

18.449.2107.071



Type 570, motor cable
to adjust the place

18.045.5023.080

Please consider the instruction!

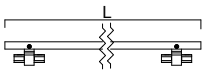

Type 570, self-closing cover strip
maximum length 1.500 mm

18.449.2101.XXX

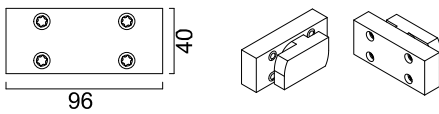

Type 570, stopper
Striker

Set 2 Stk. **449.2136.000**

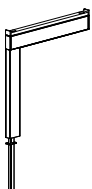

Type 570, front strut
with adjustment mechanism

18.449.2102.XXX

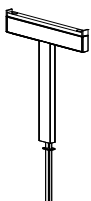

Type 570, center strut
with adjustment mechanism

18.449.2104.XXX

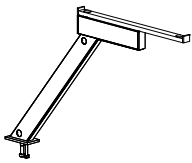
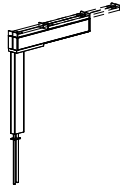
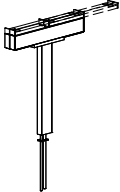
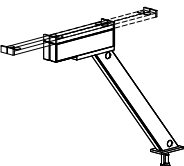
Picture	Product	Part number
	Type 570, rear strut with adjustment mechanism	18.449.2106.XXX
	Typ 570, Mittelstütze vorne mit Verschiebemechanik (2 Gleitschienen)	449.2103.XXX
	Typ 570, Mittelstütze Mitte mit Verschiebemechanik (2 Gleitschienen)	449.2105.XXX
	Typ 570, Mittelstütze hinten mit Verschiebemechanik (2 Gleitschienen)	449.2108.XXX